

PARÇA KODU PART CODE	PARÇA ADI PART NAME	s ÖLÇÜSÜ (KALINLIK) s MEASURE (THICKNESS)	Malzeme Material	Kaplama / Coating		
				SN	AG	Nİ
TŞ 2470 DP	1 NO 2.TERMİNAL Ø5.2 K.A. =DP=	0.45±0.05	(CuZn30) Pirinç / Brass	-	-	-
TŞ 2470 RP	1 NO 2.TERMİNAL Ø5.2 K.A. =RP=	0.45±0.05	(CuZn30) Pirinç / Brass	-	-	-
TŞ 2470 RPK	1 NO 2.TERMİNAL Ø5.2 K.A. =RPK=	0.45±0.05	(CuZn30) Pirinç / Brass	+	-	-
TŞ 2470 RÇN	1 NO 2.TERMİNAL Ø5.2 K.A. =RÇN=	0.50±0.05	Paslanmaz Sac(430)	-	-	-

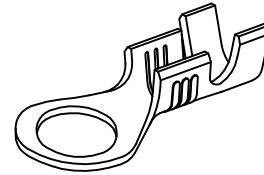

Perspektif
Perspective

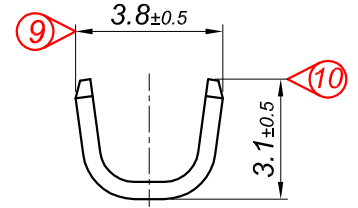
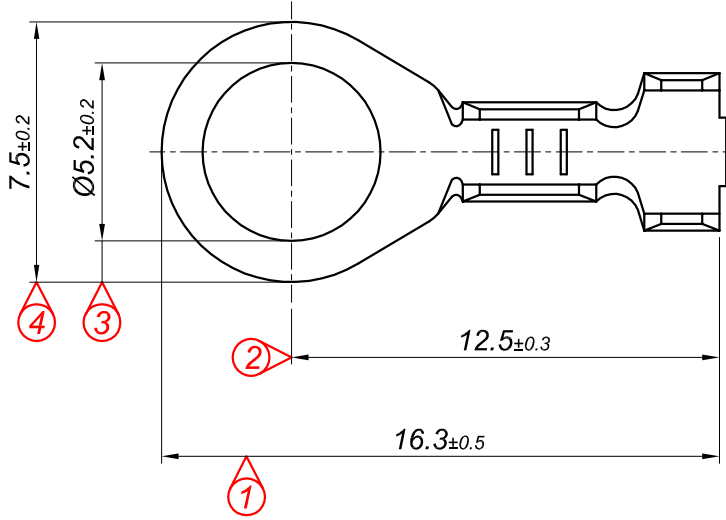
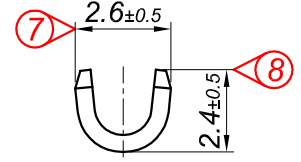
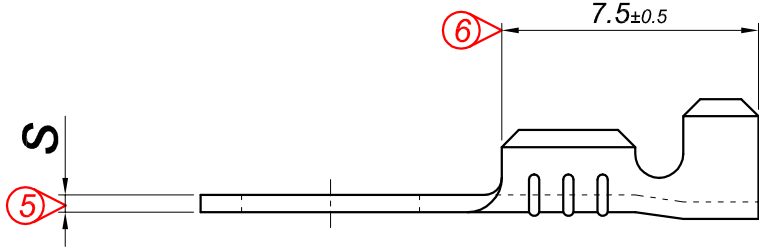
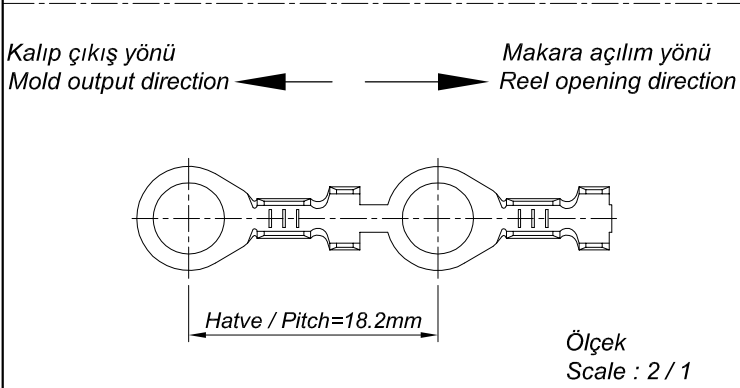

Kablo Kesiti

Wire Section : 0.25 - 0.50 mm²

Resim üzerinden ölçü almayınız
do not measure on drawing

Tarih / Date	07.12.2014	İmza /Signature	Ölçek /Scale			
Çizen / Desing	M.Yağcı					
Onay / Approval	S.Gölcük		5 / 1	No	Değişiklik / Revision	Tarih/Date



Parça Adı:
Part Name

1 NO 2.TERMİNAL
KÜÇÜK AYAK Ø5.2

Parça Kodu:
Part Code

TŞ 2470